

# Windswept

A.S. XXIX (1995)



January and February



## SHIRE OFFICERS

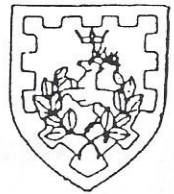

SENECHALE-Lady Isabeau d'Andrea  
Tari Stewart  
6521 Evers Boulevard  
Cheyenne, Wyoming 82009  
(307)-634-3500

KNIGHT MARSHALL-Lady Kayleigh Hayes  
Gail Barbero  
709 West 5th Street  
Cheyenne, Wyoming 82007  
(307)-778-8536

MARSHAL of FENCE- Lord Evan Embleton  
John Webb  
PSC Box 7117  
F.E. Warren AFB, Wyoming 82005  
(307)-632-1715

ARCHERY MARSHALL- M'lord Yanthlos  
Morris Stewart  
6521 Evers Boulevard  
Cheyenne, Wyoming 82009  
(307)-634-3500

HERALD- Sir Mark von dem FalkensFenn  
Mark Fenn  
716 West 28th Street  
Cheyenne, Wyoming 82001  
(307)-634-7151

TREASURER- Lady Aldith o Baddon Poeth  
Debbie Hammons  
10700 Ranch Road  
Cheyenne, Wyoming 82009  
(307)-632-1133

MINISTER of ARTS SCIENCE- M'lady  
Angelina Crispiana d'Avignon  
Rachel Rodrigues  
2607 Poplar Court Apt. B  
Cheyenne, Wyoming 82007  
(307)-778-7053

MINISTER of the LIST- Lady Thorhalla  
Bjarnadottir  
Jill McMillan  
903 Alice Court  
Cheyenne, Wyoming 82007  
(307)-634-8418

CHRONICLER- Lady Renate Koven  
Patricia Hansen  
10205 Powderhouse Road  
Cheyenne, Wyoming 82009  
(307)-635-1320

HOSPITALLER- Lord Mavrikii Andronikov  
Jim Barbero  
709 West 5th Street  
Cheyenne, Wyoming 82007  
(307)-778-8536

This is the WINDSWEPT, published by and for the members of the Shire of Windkeep, in the Kingdom of the Outlands, of the Society for Creative Anchronism Inc. (SCA). It is only a supplement to the Outlandish Herald and is not intended as a substitute. It is not an official publication of the SCA, Inc., and makes no attempt to delineate SCA policy. Articles of an informational nature published in the Windswept may be reprinted--in their entirety and without credit--without permission unless otherwise noted; rights to art, poetry, stories and othersuch creative works remain those of the Windswept and the original artist and can not be reprinted without written permission. Subscription Rates are \$4.00 per year for 6 bimonthly issues (pro-rated quarterly) beginning in January. Submissions and event announcements are due by February 20th.

## CREDITS

COVER: "Medieval Holiday's and Festivals"  
by M.P. Cosman

Music Review: M'lady Guilietta

Arrow Jig: Lord Henry

Thorrablott Customs: White Falcon and Lady Renate

Various and Sundry Illustrations: M'lady Angelina  
d'Avignon

Editor in Minor: M'lady Angelina d'Avignon

Border Designs and Clip Art: Various Art Pattern Books

# CALENDAR OF EVENTS

## JANUARY 1995

Tues.3	Calligraphy at Isabeau's
Wed. 4	Bowers Class at Yanthlos
Thur.5	Armouring at Mavellic's
Sat. 7	Caerthe's 12th Night
Tues.10	Research at the Library
Wed. 11	Garb Making at Angeline's
Thur.12	Dance Practice at Pioneer Park School
Wed. 18	Bowers Class at Yanthlos
Thur.19	Armouring at Mavellic's
Tues.24	Taster's Revel in Lion's Park
Thur.26	Populace Meeting at Laramie County Library

## FEBRUARY 1995

Wed. 1	Bowers Class at Yanthlos
Thur.2	Armouring at Mavellic's
Tues.7	Calligraphy at Isabeau's
Wed. 8	Garb Making at Angeline's
Thur.9	Dance Practice at Pioneer Park School
Tues.14	Research at the Library
Wed. 15	Bowers Class at Yanthlos
Wed. 15-20	Estrella War XI
Thur.23	Populace Meeting at Laramie County Library
Tues.28	Taster's Revel in Lion's Park

## ARTS and SCIENCE COMPETITION

Arts and Science Competition will be held during January Taster's, Tuesday the 24th: The January's categories will be armorial arts, jewelry, open class, and there will be a "People's Choice" award: Check the year's schedule of Arts and Science Competitions and the categories for each event:

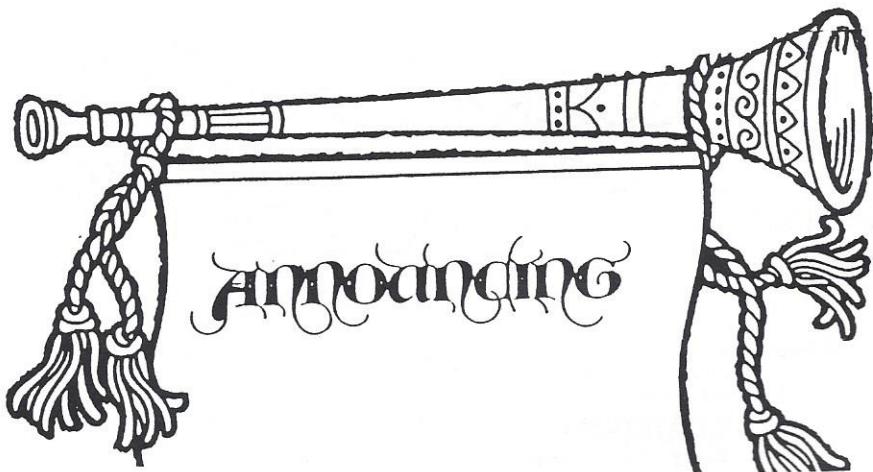

Fighter Practice for January and February is undetermined at the time of this printing. Contact Lady Kayleigh at 778-8536 for information and availability of a ride to neighboring fighter practices.

Archery is on winter hold. Contact Rhys at number 632-1133.

Armouring is Thursday evenings at Lord Mavrikii's. Contact number is 778-8536

Calligraphers is the first Tuesday evening of each month at Lady Isabeau'. Phone 634-3500.

Bowers Class is the first and third Wednesday evenings at m'lord Yanthlos Phone 634-3500.

Brewing is done on a one to one base. Contact Lord Mlodn if interested at 635-1320

Garb Making is on the second Wednesday of each month at 2607 Popular Court Apt. B from 7pm to 9pm. Call Angelina at 778-7053.

Dance Practice is being held the second Thursday of the month at Pioneer Park Gymnasium. Donations are needed to keep this self-supporting. For more information contact Aildhanna (Alikina) Mac Aipean at 632-9036.

Research at the Laramie County Library will be the second Tuesday of each month at 7:00 P.M. Call Sir Mark at 634-7151.

Tasters Revel and Dancing is the fourth Tuesday at the Lions Park Community Center from 7:00 to 10:00. \$4.00 Feast and Site, or \$1.00 fee for Site only. Feast is by RESERVATION ONLY. For more information contact Lady Aldith, 632-1133

If you wish to prepare the feast for the monthly Tasters Revel please contact Lady Aldith for times available and other information at 632-1133.

The POPULACE MEETING is held the fourth Thursday of the month in the Laramie County Library at 7:00 PM.

**\*ARTS AND SCIENCES WINDKEEP CHAMPION\***

In August of 1995 a Champion will be chosen that shows great skills in the gentler arts. This Champion should show excellence in at least one skill and knowledge of one or two others. Documentation will be required. Please start your projects now and become Windkeep's first A and S Champion.

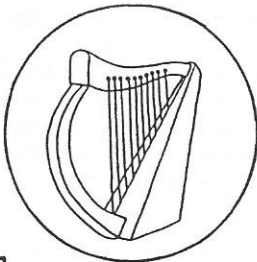

A GRIFFIN'S EYEVUEW OF ARTS & SCIENCE  
EVENTS FOR A.S.XXIX \* 1994 GREGORIAN

Unto all who come by these letters,  
Do we of Windkeep, Send Greetings \*

We invite you to participate in the  
goodly ~~competition~~ of gentle arts.

**January** \* ARMORIAL ARTS \* JEWELRY \* OPEN

January Taster's, Jan 24<sup>th</sup> is the site for  
the exhibits. "People's choice" will also be a  
means to express appreciation to the artisans of  
Windkeep and visiting artisans from the surround-  
ing area.

**April** \* COSTUME \* PERFORMING ARTS \* OPEN

April Taster's, April 25<sup>th</sup> hails the beginning of  
Summer events which include boisterous battles and  
bardics. Let us set the stage with bright colors  
and heroic ballads of noble deeds and courtly Love.  
Be invited into the merry madness of Springtime.

**August** \* A&S CHAMPIONSHIP\* PEOPLE'S CHOICE\*

August, WINDKEEP DEFENDER, Aug. 5<sup>th</sup> presents  
The Best of Windkeep. Artists and Fighters join  
forces to express the best qualities of these  
Current Middle Ages. Honor and Chivalry will be  
the qualifying standards for all entries of this  
Windkeep Event. Prepare the Best \* Enjoy the Most.

**November** \* COOKING \* SCROLLS\* OPEN\*

November Taster's, Nov. 28<sup>th</sup> thanks the Populus  
of Windkeep for a fruitful and exciting season of  
Arts and Science exhibits and a challenging season  
of Archery and Fighting. Thankful appreciation to  
All.

\*\*\* IN HONOR AND CHIVILARY \* PLAY ON \*\*\*

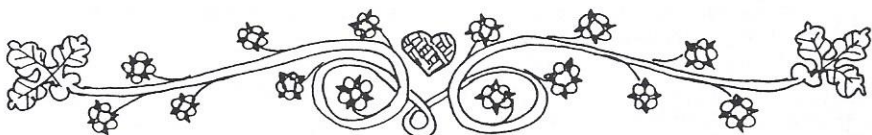



## Thorrablót Customs

The word "Thorrablót" was first used in the Middle Ages when old King Thorri, who was a great one for sacrifices, made one every year in the middle of winter. According to an old Icelandic calendar, there were only two seasons, winter and summer. Time was measured by counting the weeks of each season. Thorri is the fourth Old Norse winter month, which begins on Friday of the 13th week of winter. This year it falls on February 3rd.

Jon Arnason's "Icelandic Folk and Fairy Tales" describes it as "the duty of the farmer to welcome Thorri" by rising earlier than anyone on the farm the first morning. He was to rise and go outside only in a shirt, barefoot, and partly barelegged. He was to hop on one foot around the farmhouse, still dragging his pants on the other foot and bid Thorri welcome to his home. In some places in northern Iceland the first day of Thorri is called "husbands day" and the men are supposed to be treated well by their spouses.

When Christianity was adopted, sacrifices to heathen spirits were prohibited, and since there were plenty of major ecclesiastical festivities around this time, thorrablót was almost forgotten. However Thorrablót was rekindled by Icelandic students in 1873. It took about 90 years before the custom spread throughout Iceland. At that time also, the word "Thorrafood" began to be seen in print. Actually, Thorrafood is just traditional Icelandic dishes prepared the way people were forced to do it in earlier times, when necessity and primitive methods of preservation demanded total utilization of their livestock. Food was smoked, salted, dried, pickled or fermented. Thus, what once was a manifestation of dire need has now become a delicacy.

The principle kinds of Thorrafood are the following:

HANGIKET (hung meat) which is smoked lamb or mutton.  
HVALRENGI-pickled whale blubber.  
HAKARL-fermented shark meat which has ripened by burial for a certain length of time to make it decompose.  
SVID-roasted sheep head. The sheep heads are burnt with a torch to burn the wool off. They are then sawed in half, washed and boiled in water. The sheep heads are served with mashed potatoes and mashed turnips.  
SVIDASULTA-the meat from the sheep head used to make headcheese.  
HRUTSPUNGAR-soured (pickled) rams' testicles  
LUNDABAGGAR-(loin bags) which are sausages made from the neck tissue wrapped in the colon, sewed shut and boiled.  
BLODMOR-blood pudding. Blood from a lamb which is taken and mixed with animal fat.  
LIFRAPILSA- liver sausage. Liver is ground two or three times in an ordinary meat grinder. Then it is mixed with animal fat and rye-meal. This mixture is stuffed into sheep stomachs and then boiled. The sausages can also be boiled, let cook, and then sliced and fried in a pan served with sugar on top.  
HARDFISKUR-dried fish, ysa. We call this fish haddock  
FLATKOKUR-flat bread  
RUGBRAUD-rye bread

Pickling the Icelandic way is with lactic acid obtained from sour milk or whey.

The experience of tasting these foods is one I will never forget and I promise I will not have a Thorrablót Event because I don't know where I could find these food delicacies in our entire region.

# F.Y.I.

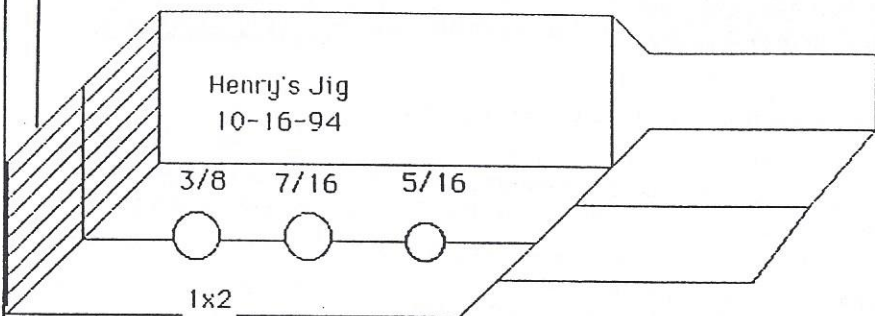

Sand paper on bottom. Hinged with canvas.  
This is a jig designed by Lord Henry  
to sand arrow shafts smooth after  
being planed down from 3/8" square  
piece of wood.

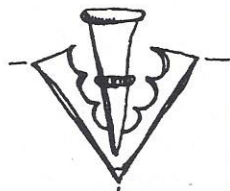

MUSIC REVIEW, by GIULIETTA of FLORENCE

THE SERAPHIM GUIDE TO RENAISSANCE MUSIC  
SYNTAGMA MUSICUM OF AMSTERDAM

MUSIC ERA : 1200 - 1600 AD

3 record set music anthology. Available at public  
library in Cheyenne, Wyoming. Text of music missing.

In my opinion, this three record set is quite a gem. It has some scratches and skips from being used. But that doesn't hinder the spirit or emotion. All songs have titles, acknowledgement of composers (if they are known), and a list of instruments played. Since I obtained this anthology on loan from the library, I invite all to have the opportunity of checking it out. And listen to the transition of history. Although the text is missing, there are some famous composers on the anthology. This includes King Henry VIII, Guillaume de Machaut, John Dunstable, Dufay, King Richard the lion hearted (Richard I of England), and Adam de Halle. Also other known composers, as well as anonymous composers. The singing is a little monotonous and the tempo from some of the music is very slow. Aside from that, this anthology is beautiful and well worth a try.

# War Practice

Prepare Ye Now For War! January 8th and 22nd War Practice will be held at Jefferson County Fairgrounds in the general purpose building.. If luck is with us and the weather is good we may be able to move outside to one of the ballfields as we did last year. Remember The Outlands is one of the principles at Estrella War this year, plan to attend one or both of these practices to hone your skills for use against Atenveldt.

WHEN: January 8 and 22, 1995 10:00 - 6:00

WHERE: Jefferson County Fairgrounds, general purpose building, 15200 W. 6th Ave, Golden. DRY SITE.

FEE: Brass Bowl

DIRECTIONS: I-25 to 6th Ave West, 6th Ave to Indiana exit; south (left) of the exit to 6th Ave Frontage Road (1st light past on/off ramps); west (right) on Frontage Road to fairgrounds entrance (it will be on your left); follow entrance road up to buildings; general purpose building is the first on the right.

AUTOCRAT: Lady Cecelia Corr Mhaire (Mary Conley) 433-0132, 556-2270

## Windkeep Fighters

For more information contact;  
KNIGHT MARSHALL-Lady Kayleigh Hayes  
Gail Barbero  
709 West 5th Street  
Cheyenne, Wyoming  
(307) 778-8536

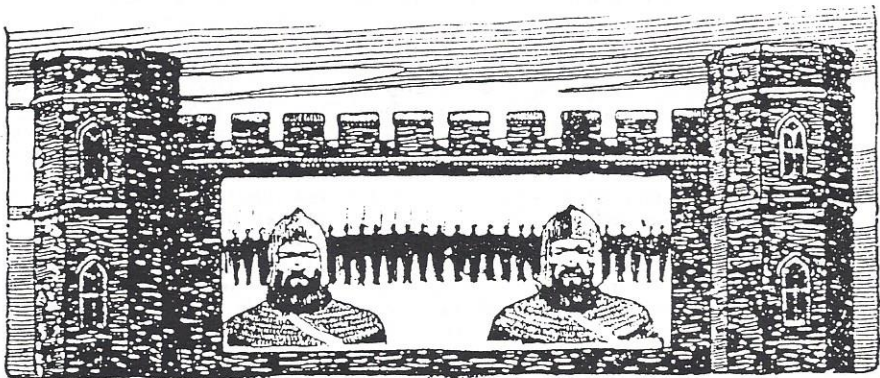





**Where:** Estrella Regional Park - 15099 Casey Abbot Road North - Goodyear, AZ  
**When:** February 15-20, 1995 - Gate will open at 10:00 a.m. Wednesday, February 15.  
**Fees:** **Site Fee,** \$30.00 each Wednesday to Monday; \$25.00 each Friday to Monday; Per Day Fee-\$15.00; There is a \$5.00 discount with proof of membership.  
**Merchant Fees** (in addition to site fee): \$55.00 single space; \$90.00 double.  
**Entry:** No personal checks accepted, please have your Fighter Authorization and proof of membership ready at the gate.

Greetings One and All from those lands kissed by the Sun. As the winds and rains once again cross our lands from the depths of Argonia, attention turns to preparations for this tremendous Estrella War.

This year the Armies and Artisans of Atenveldt shall meet their brothers from the Outlands upon the fields of Estrella. The noble Armies of Caid shall be attending to balance the sides as the Outlands had done the previous year. We invite the Knowne Worlde to attend and enjoy six days of Fighting, Arts, Camaraderie, Revelry and Shopping!

This year we have expanded the site with a larger and more accessible Merchants Row (set in a new portion of the Park, east of the Fighting Field.) To the south of Merchants Row (in the tree grove) we have reserved a large space for "Enchanted Ground." Everyone who wishes to take part in this area is cordially invited to attend.

With the moving of Merchants Row to a more spacious area, we now have a great deal more camping space. The eastern camping area of the park will be "Sleepy Hollow" for all you early risers. The rest of the Park is there for your enjoyment as normal. The park has improved the shoulders of the road to allow "head in" parking instead of parallel. Huzzah! This should relieve a great deal of the parking headaches.

If you wish to rent a pavilion, please contact Tri-Rentals, (602) 966-3474. This is not the same tent company as last year and we believe that this will resolve many of the difficulties we've experienced in the past (the autocrats are NOT responsible for any hassles that may occur as a result of using a mundane vendor!) Ask for Estrella War information or Mr. Ed Ayo (they have literature in the information packet, see listing below) as they have special pricing and packages just for us at volume discount levels.

As usual, weather is unpredictable in the Great Southern Desert. Be prepared for anything from hot days, to cold nights, to rain and wind. All flames must be enclosed in a container; fire-pits, lanterns and enclosed torches are fine--open candles and unscreened tiki torches are not. Please bring a fire extinguisher for each tent by order of the City of Goodyear Fire Marshal. All minors not accompanied by their parent must have a NOTARIZED Minor's Waiver and Medical Waiver (your Seneschal should have these.)

Once again, there are NO accommodations for horses. Please don't bring them. That's the park's ruling, not ours--they will not be allowed into the park. All pets must be kept on leashes, or secured in your camp. There will be no pets allowed in the food areas of Merchants Row. Animals found running loose will be turned over by the Park Rangers to local animal control officers.

For more information, send a SASE with 2 (that's two) stamps to: Estrella War XI--  
Information Packet: P.O. Box 35190, Phoenix AZ 85069

**Autocrats:** Cherie Ruadh MhicRath of Locksley, P.O. Box 35190, Phoenix, AZ 85069  
internet: locksley@indirect.com

Petruccio Alfonso Maria Cuccieri de Cataluna, internet: petrucio@indirect.com

*Until we meet & clasp hands in friendship, may your herds multiply  
and your enemies run before your approach.*

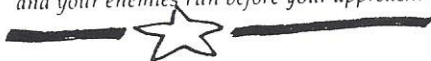

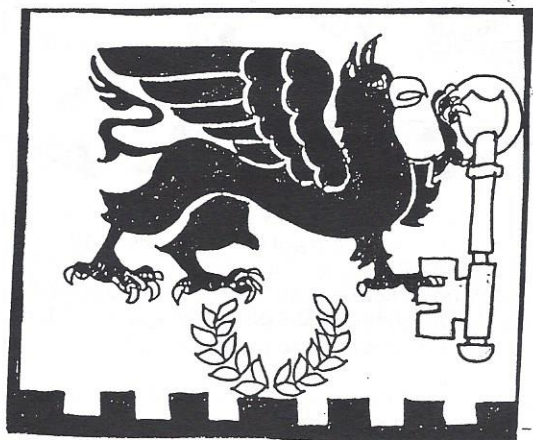

# "HISTORY"

From the information I've been able to put together I'd like to show the history of our shire as I've researched from past issues of the Windswept which has always been the newsletters name. In February 1982 there was a Frontier Army Sweetheart Ball at the Recreation Center at F.E. Warren Air Force Base. Quite by accident, several people, while talking learned that they were SCA members and/or knew others. In all ten members were present. It was decided to meet in two weeks and the shire was born. The first name considered was "Windraven", but was modified to "Windhaven" for submission. Not passing, "Winddragon" was tried (in about 1985) and also failed (there was a Windwyvern). Staying with birds, the next try in January AS XX (1986) was "Gryphon's Keep" (there was a Gryphon's Tower), again failure. The last try was with the "Windkeep" passing in March AS XXI (1987). We started in the Principality of the Outlands Kingdom of Atenveldt. We were for the split that resulted in the Principality moving up to kingdom. The shire made kneeling pillows for regalia for the first Outland crown on June 14 AS XXI (1986). By our reckoning this is the list of Seneschals:

Nicholai the Wanderer  
Galen of Wiltshire  
Bevan d'Ormand  
Talon the Seeker  
Brian of Winterhaven  
Tod Coyle  
Ceallach Treman  
Thalia Loryn of Winddragon  
Maelgwn the Traveler  
Rhys Afalwin  
Kayleigh Hayes  
Isabeau d'Andrea

April 1982 to ?  
? to  
January 1984 (AS XVIII) to  
September 1984 (AS XIX) to  
December 1984 (AS XIX) to  
March 1985 (AS XIX) to  
November 1986 (AS XXI) to  
March 1987 (AS XXI) to  
July 1988 (AS XXIII) to  
September 1990 (AS XXV) to  
December 1993 (AS XXVII) to  
October 1994 (AS XXIX) to

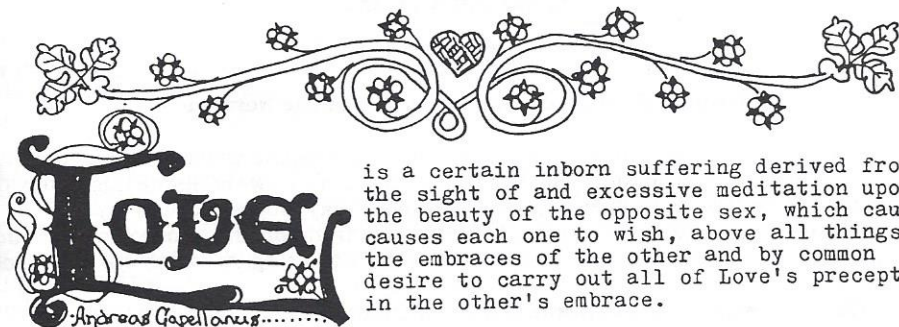

is a certain inborn suffering derived from the sight of and excessive meditation upon the beauty of the opposite sex, which causes each one to wish, above all things the embraces of the other and by common desire to carry out all of Love's precepts in the other's embrace.

# Love

Andreas Capellanus.....

- i Marriage is no real excuse for not loving.
- ii He who is not jealous, cannot love.
- iii No one can be bound by a double love.
- iv It is well known that love is always increasing or decreasing.
- v That which a lover takes against the will of his lover has no relish.
- vi Boys do not love until they arrive at the age of maturity.
- vii When one lover dies, a widothood of two years is required of the survivor.
- viii No one should be deprived of love without the very best reasons.
- ix No one can love unless he is impelled by the persuasion of love.
- x Love is always a stranger in the house of averice.
- xi It is not proper to love any woman whom one would be ashamed to seek to marry.
- xii A true lover does not desire to embrace in love anyone except his beloved.
- xiii When made public, love rarely endures.
- xiv The easy attainment of love makes it of little value; difficulty of attainment makes it prized.
- xv Every lover regularly turns pale in the presense of his beloved.
- xvi When a lover catches sight of his beloved, his heart palpitates.
- xvii A new love puts to flight an old one.
- xviii Good character alone makes any man worthy of love.
- xix If love diminishes, it quickly falls and rarely revives.
- xx A man in love is always apprehensive.
- xxi Real jealousy always increases the feeling of love.
- xxii Jealously, and therefore love, are increased when one suspects his beloved.
- xxiii He, whom the thought of love vexes, eats and sleeps very little
- xxiv Every act of a lover ends in the thought of his beloved
- xxv A true lover considers nothing good except what he thinks will please his beloved.
- xxvi Love can deny nothing to love.
- xxvii A lover can never have enough of the solaces of his beloved.
- xxviii A slight presumption causes a lover to suspect his beloved.
- xxix A man who is vexed by too much passion usually does not love.
- xxx A true lover is constantly and without intermission possessed by the thought of his beloved.
- xxx1 Nothing forbids one woman being loved by two men or one man by two women.

The Horizon Book of the Middle Ages, American Heritage Publishing Co., New York, 1968.



# Candlemas

February 4

**Protect us, O Lord, from the wrath of the Northmen!**

Good gentles, pray attend! The Barony of Dragonsspine wishes to announce its plans to celebrate the coming of Candlemas. Please join us as we celebrate this year with a Viking theme. The day will resound with Northern play, pugnacity, and repast.

This year's festivities will be entirely Northern in tradition and atmosphere. Barring a killer snow storm, this years Candlemas will include **fighting!** Activities will consist of:

**Odin's Ordeal** - a masochist flavored fighting tourney with a Viking flair.

**Valkyries' Fire** - a ship board fencing tourney.

**Bragg's Tongue** - an insult and challenge match.

**Ragnar's Rags** - a contest for the most authentic Viking garb.

Prizes will be awarded for all these competitions. The prize for Ragnar's Rags will be donated by The Honorable Lady Brilliana, Baroness of Dragonsspine, and will include rare scented oils and precious spices from the Far East. No documentation is requested; the costumes will be judged on their appearance.

For those good gentles with a hearty Viking appetite, a feast will be provided by Duchess Selene. Fare will reflect a Northern banquet style. Due to our theme, fare will not be provided for vegetarians, but off-board seating will be available. The Dragonsspine Brewers and Vintners Guild will also host a tasting competition and silent auction.

For those with interest in things Heraldic, the Heralds Guild will be on hand to answer your questions about devices, names, submissions, and heady colorful suchlike.

This year's Candlemas promises to be truly period and a

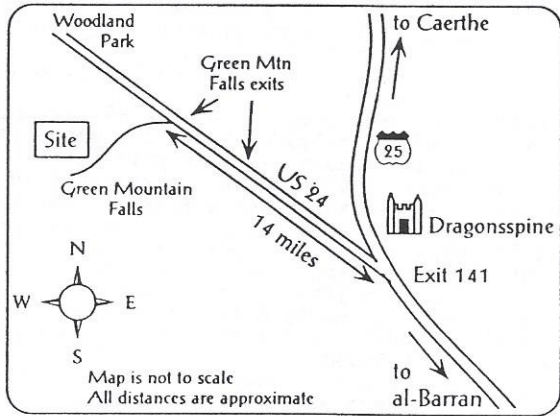

smashing good time for all Outlanders with a love of Northern "festival".

The site for this year is the Sallie Bush Community Center. Directions and further activities will be included in the next *Outlandish Herald*. For more information, contact your barbaric autocrat.

Site fee is \$7, with a \$3 discount for members. Feast cost is \$8 for adults, children 6-14 are \$4, and children 5 and under are free.

Autocrat: Lord Talon the Wicked (Shawn McKenna)  
(719) 597.4944

## THE EPIC TALE OF ALLERGICUS UDDERUS

For those of you who may not yet be acquainted with the "cow tails" of the great founder of Bo Farrach, (and especially for those who are) lend me your eye! I shall begin at the beginning of the heroic epical farce and recapitulate his noble origins.....

It is not widely known that the founder of Rome, Aeneas, had a younger brother, Allergicus Udderus. Aeneas and Allergicus fled from the sack of Troy in two ships, hotly persued by the Greeks (there are obscure Homeric references to unpaid gambling debts ..). They were both blown onto the shore of Carthage by a fierce storm, where they sought refuge and solace. Aeneas sought refuge with the legendary Queen Dido and Allergicus sought solace in a more liquid form at Queen Dido's Bar and Grill. Queen Dido grew to love Aeneas but he would not marry her. Instead, he set his face toward Italy and his story was magnified to make the Roman Top Ten Bestsellers.

Allergicus had set his face in pursuit of a more liquid destiny and could not pay his bar tab at Queen Dido's Bar and Grill..Great was the queen's wrath at these two brothers (for no one likes being stiffed on either account). Mounting the pinnacle of the Temple of Baal she called down curses on them both. She cursed the destination of Aeneas then set upon his brother with, "Allergicus Udderus will pay his bar tab before he dies, SO HELP ME BAAL!" And so it was that because of Queen Dido's curse and his sense of honor, Allergicus lived far beyond the normal span of years.

Weaving unsteadily North and West our noble first father stopped in Mystical Avalon. Well...shipwrecked actually. Exploring inland Allergicus Udderus came upon a broad valley with a lake in the center. In the midst of the lake was an island. On the island was an eagle perched on a cactus, eating a snake in it's talons. A sword rose from the waters of the lake held by a slender silver mail clad hand. A cruciform descended from the clouds, and a majestic voice boomed, "By this sign shall you conquer!", a silver chalice materialized in the air before him, spinning slowly before his eyes. Allergicus hiccuped, said, "Nope, this ain't it" and sailed for greener pastures.

...The Epic continues with each chapter illuminating the "true" history of many of your favorite historical characters. Follow Allergicus Udderus as he weaves through Ireland, The Middle East, Spain, China, Mongolia, Japan, The New World...You name it, he has been there. For those of you who wish to know more about our abrogated patrician Allergicus, Lord Timon Phocas of Bo Farrach has compiled these first hand accounts reputedly told by the ancient progenitor himself! We have the complete Illuminated, Illustrated, Annotated, Re-edited version (with chapters never-before-seen!) available now for the low, low price of only \$5.50 for each copy of this 40 page novelette (which includes shipping.) Make your checks out to SCA Unser Hafen and send to:

Lady Lughbec ni Eoin  
c/o Nancy Lynch  
1941 Sixth Avenue  
Greeley, CO 80631

These funds will be used for Bo Farrach's much needed fencing, fighting, archery, boffer gear, loaner garb and to assist with Bo Farrach's and Unser Hafen's Estrella War practice sites.

Unto the good genties of the shire of Windkeep doth Isabeau send greetings on this extremely busy and festive time of year.

With Hunters Feast being Windkeep's final event for the year, I wish to thank all the populace and autocrats for the work and support that you have shown to our shire and to me. I do hope in the coming year that Windkeep can fullfill some of your more pleasant times.

I wish you all the best in this coming year.

In service to you,

Isabeau

---

I have received several positive comments about the last two Windswepts I have done. Thank you for the input. I do welcome suggestions, criticisms, articles, recipes, YES ANYTHING related to the middle ages. I do encourage the people from other shires to send me information about their events that they might wish us to put in our newsletter. Do keep in mind that we are putting out the Windswept every other month. The deadline date for the following months is inside the front cover.

If you haven't gotten your subscription to the Windswept for the year, it is not too late. It is ONLY \$4.00 a year, OR 75 cents plus postage, if I have to mail it. If you pick it up from me, it will only be the 75 cents

A few extra copies might be available from either the chronicler or the hospitaller.

Lady Renate Koven, Chronicler for the Shire of Windkeep.

*Renate*

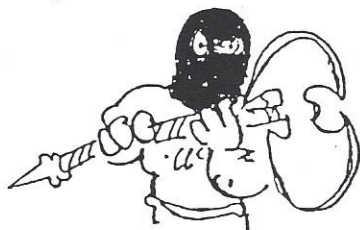

SUBSCRIBE!!

SUBSCRIBE NOW !!! SEE BELOW !!

ITS DECISION TIME.

Want to continue being a barbarian, missing meetings, and not knowing when or where events are being held. Get civilized and subscribe to the Windswept.

Yes even you can be knowledgable, popular, good looking, well liked, rich, noble, informed, intouch, etc., etc., etc., guaranteed. Well at least the last three. Subscribe today.

INSTRUCTIONS

Place your name on the line titled "Name", place your mundane name on the line titled "Mundane Name", place your mailing address on the line titled "Address", place your state on the line titled "State", and place zip code on the line titled "Zip". Now you are nearly done, write a check to "SCA Shire of Windkeep" for \$4.00, mail the form and the check to the Chronicler at Windswept, c/o Patricia Hansen, 10205 Powderhouse Road, Cheyenne, Wyoming, 82009-9689.

MEMBERSHIP LIST

Shire membership list is available separately for \$.75 from the Chronicler and \$1.00 postpaid. Membership list mailed free with subscription now.

SUBSCRIPTION TO THE WINDSWEPT MARCH TO DECEMBER  
FIVE (5) ISSUES \$3.25

Name \_\_\_\_\_

Mundane Name \_\_\_\_\_

Address \_\_\_\_\_

State \_\_\_\_\_

Zip \_\_\_\_\_

Optional Telephone ( )-\_\_\_\_\_ \$3.25

Enclosed \$.75 for membership list \$ .75 or  
\$1.00

Enclosed \$4.00 or  
\$1.00

!!!! SEE ABOVE !!

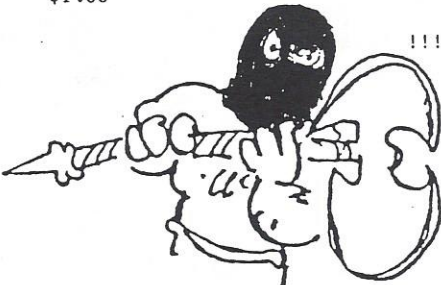

SUBSCRIBE!!

# Windswept

C/O Pat Hansen  
10205 Powderhouse  
Cheyenne, WY 82009

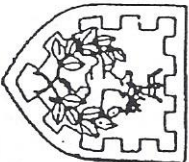
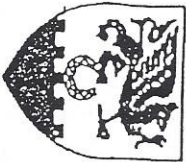

Seneschale

*Timed value - Do Not Delay*